

# Architecture and Preliminary Design of a Fuzzy Logic-Based Microbattery Charge Controller

Jagadeesan Rajagopalan and Pritpal Singh  
Dept. of Electrical and Computer Engineering  
Villanova University  
Villanova, PA 19085

Rodney LaFollette  
Bipolar Technologies, Inc.  
4724 Brentwood Circle  
Provo, UT 84604

and

David Reisner  
US Nanocorp, Inc.  
74 Batterson Park Rd.  
Farmington, CT 06032

## Abstract

MEMS devices currently lack an integrated power supply that can provide significant on-chip power to the MEMS devices while being packaged with the devices. Bipolar Technologies has developed a microbattery technology in which conventional silicon microelectronic fabrication techniques are used to manufacture cells  $\sim 10,000 \mu\text{m}^2$  ( $0.01 \text{ mm}^2$ ) in area. These rechargeable cells based on both Ni-Zn and Li-Ion chemistries have demonstrated high current delivery capability ( $\text{mA}/\text{cm}^2$ ) and good cycle life ( $>2,000$  cycles). To integrate this into a micropower supply, an energy scavenger (capable of extracting energy from the local environment) and a microbattery charge controller are required.

In the present work, the hybrid integration of a high efficiency silicon solar cell and a microbattery charge controller with Bipolar's microbatteries is being developed. In this paper, we will describe the architecture and preliminary design of a fuzzy logic-based microbattery charge controller under development.

## Introduction

Microelectromechanical systems (MEMS) device-based systems offer the prospect of very small size sensors. However, an important tradeoff currently exists in terms of how small a MEMS-based system may be made versus the functional capability of the system. This limitation of present MEMS-based systems is primarily constrained by the lack of existence of a suitable micropower supply to power the MEMS-based systems. Typically, the power source used is a small button cell.

Over the last four years, Bipolar Technologies Corp. (BTC), in collaboration with researchers at Brigham Young University (BYU), have developed a microbattery technology that can be fabricated in a silicon wafer using conventional microelectronic wafer fabrication techniques [1,2]. Both Ni/Zn and Li-ion microbatteries have been developed, with the Ni/Zn technology in a more advanced state of development. The Ni/Zn cells have demonstrated over 2,000 charge/discharge cycles when cycled through a profile that comprises several minutes of constant 50  $\mu\text{A}$  discharge followed by a 10 ms, 1 mA pulse discharge. These Ni/Zn cells are typically 1.9 mm x 1.3 mm in size and offer a capacity of 1-2 mAh/cm<sup>2</sup> and a few thousand cells may be fabricated on a single 100 mm diameter wafer.

While a single microbattery may provide power for several hours, depending on the application, for more extended applications, some means of recharging the microbatteries is required. One approach is to interface a silicon solar cell to the microbattery that can convert locally available light to recharge the microbattery. Recently, researchers at SunPower Corp. have successfully designed and fabricated very small (2.3mm x 2.3 mm), “chip-size” silicon solar cells for concentrator applications [3]. These cells are fabricated in a point contact configuration and have demonstrated >18% efficiency with short-circuit currents > 7A/cm<sup>2</sup> under concentrated sunlight (25W/cm<sup>2</sup>).

The missing link between the microbattery and the small area solar cell that is required to create a small area, integrated, micropower supply is a charge controller that controls the charging current supplied to the microbattery from the solar cell. In this paper we present the architecture and preliminary design of a charge controller for an integrated micropower supply. This charge controller employs a fuzzy logic approach to controlling the charging current.

### Microbattery Charge Controller Architecture

The basic topology of the charge controller is a step-down dc-dc (buck) converter as shown in Fig. 1. The output current from the solar cell is controlled by the switching of a MOSFET switch by a pulse width modulator (PWM) whose duty cycle is controlled by the fuzzy logic charge control algorithms. During the time that the MOSFET switch is on, the inductor is charged and current flows from the solar cell to the microbattery. The diode is reverse-biased and does not conduct during this phase of the switching cycle. When the MOSFET switch is off, the inductor discharges current through the microbattery via the diode which conducts during this phase of the switching cycle. A

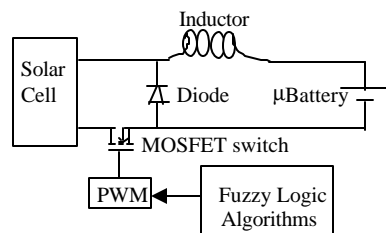

Figure 1. Basic Buck Converter Topology of Charge Controller

more detailed block diagram of the charge controller architecture is shown in Fig. 2. The charge controller comprises three application specific integrated circuits (ASICs):

- 1) A buck converter ASIC
- 2) An ASIC (ASIC II) that integrates the analog data acquisition, conditioning and conversion hardware, and
- 3) A digital controller ASIC in which the fuzzy control algorithms are implemented.

The design of each of these ASICs is presented in detail in the next sections.

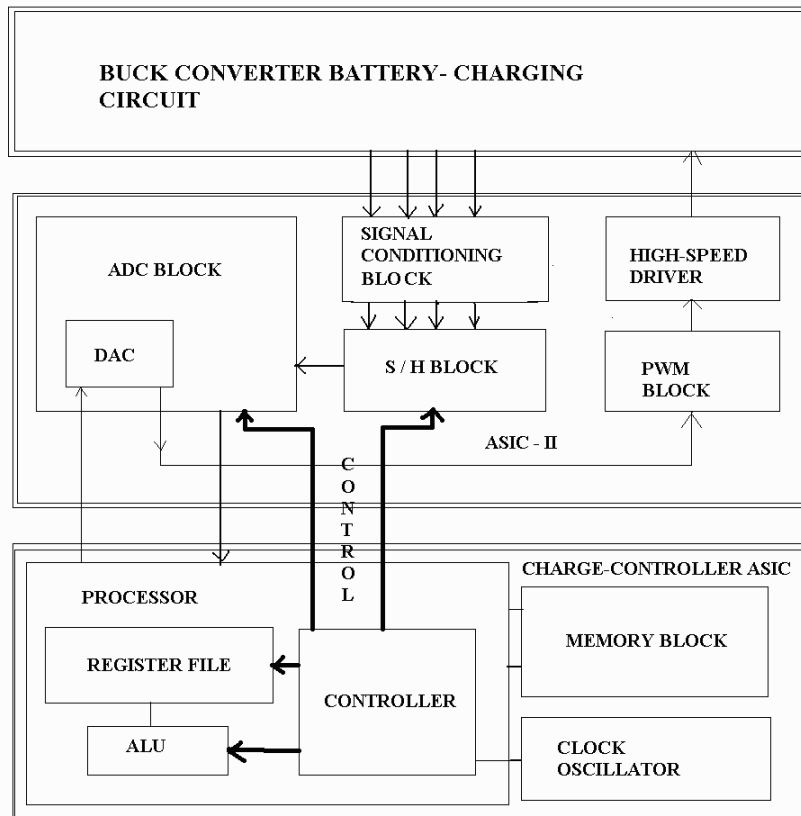

Figure 2. Detailed architecture of the Microbattery charge controller

### **Buck Converter ASIC**

To minimize power losses in the buck converter, the diode/MOSFET switch combination of the conventional buck converter topology (Fig. 1) is replaced by a CMOS transistor pair, since the diode and MOSFET switching is complementary (see Fig. 3). Several additional techniques may be used to minimize the power losses in the buck converter circuit including zero-voltage switching (ZVS) and adaptive delay time control [4]. The detailed design of the buck converter ASIC is still to be initiated.

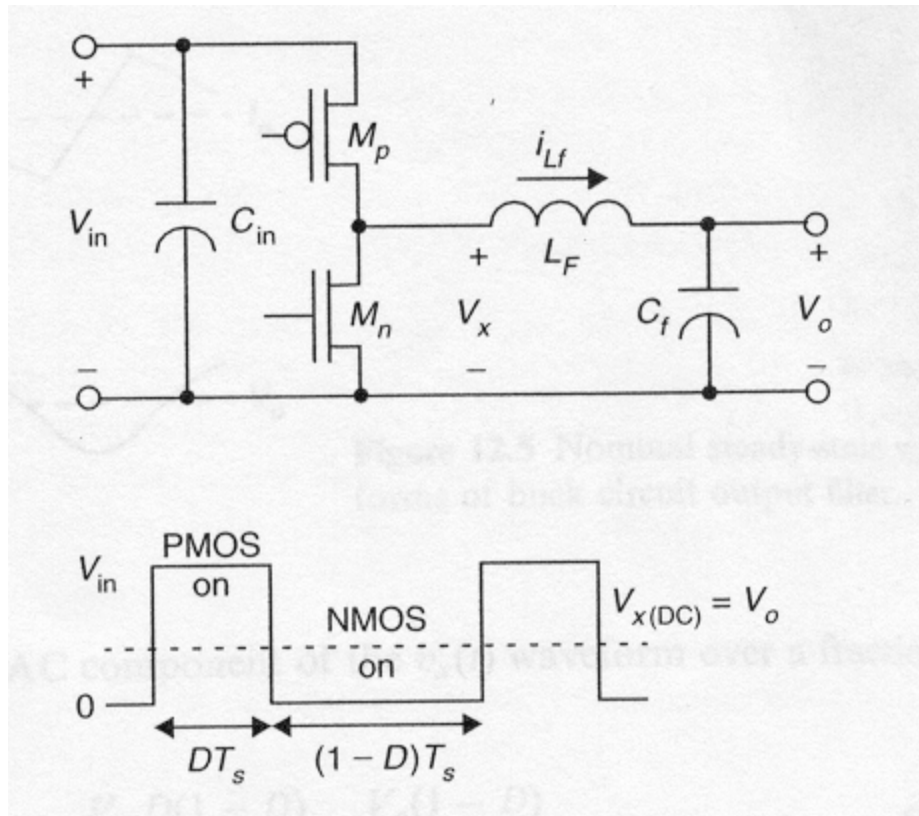

Figure 3. Low-Power Buck Converter Circuit

### Analog/Mixed Signal ASIC (ASIC-II)

The charging current from the solar cell to the microbatteries is controlled based on the monitoring of four analog, input control variables – the solar cell and microbattery voltages, the microbattery charging current, and the present value of the PWM control voltage. These four analog signals must first be conditioned to fall into a common voltage range (e.g. 0 to 5V) and then buffered through a sample and hold circuit before being digitized by an analog-to-digital converter (ADC). These digitized input signals are then fed to the digital controller ASIC where they are processed by the fuzzy logic control algorithms which results in a digital control voltage output. This digital control signal is then converted back to an analog control voltage by the digital-to-analog converter (DAC). This analog control signal is then fed to the PWM block to control the duty cycle of the pulse width modulator output (and hence the duty cycle of the MOSFET switch). A MOSFET driver is required between the PWM block and the MOSFET switch to provide a high drive current to rapidly switch the MOSFET to minimize MOSFET switching losses.

To date, 8-bit ADC and DAC have been designed and laid out at the transistor level based on a straightforward capacitor, successive approximation implementation.

## Digital Controller ASIC

The purpose of the digital controller ASIC is to implement the fuzzy logic control algorithms that determine the charging current from the solar cell to the microbattery. A more detailed diagram of this ASIC is shown in Fig. 4. The digitized, sensed control signals enter the controller from the ADC (top right of Fig. 4) and are fed to a register file where this data is temporarily stored. This stored data is run through the fuzzy logic algorithm which is stored in a memory module (this may be external memory or on-chip FLASH memory) and an output control signal is fed out to the DAC (from the bottom right of Fig. 4).

The architecture of this controller is a complex instruction set computer (CISC). The 8-bit central processor unit (CPU) has 2 accumulator registers A and B, which can also be addressed as a combined 16-bit register D. There are 2 16-bit registers IX and IY for direct memory addressing. All the registers, including a temporary register and a special ADC\_out register that stores the output from the ADC, are modeled as a Register-file.

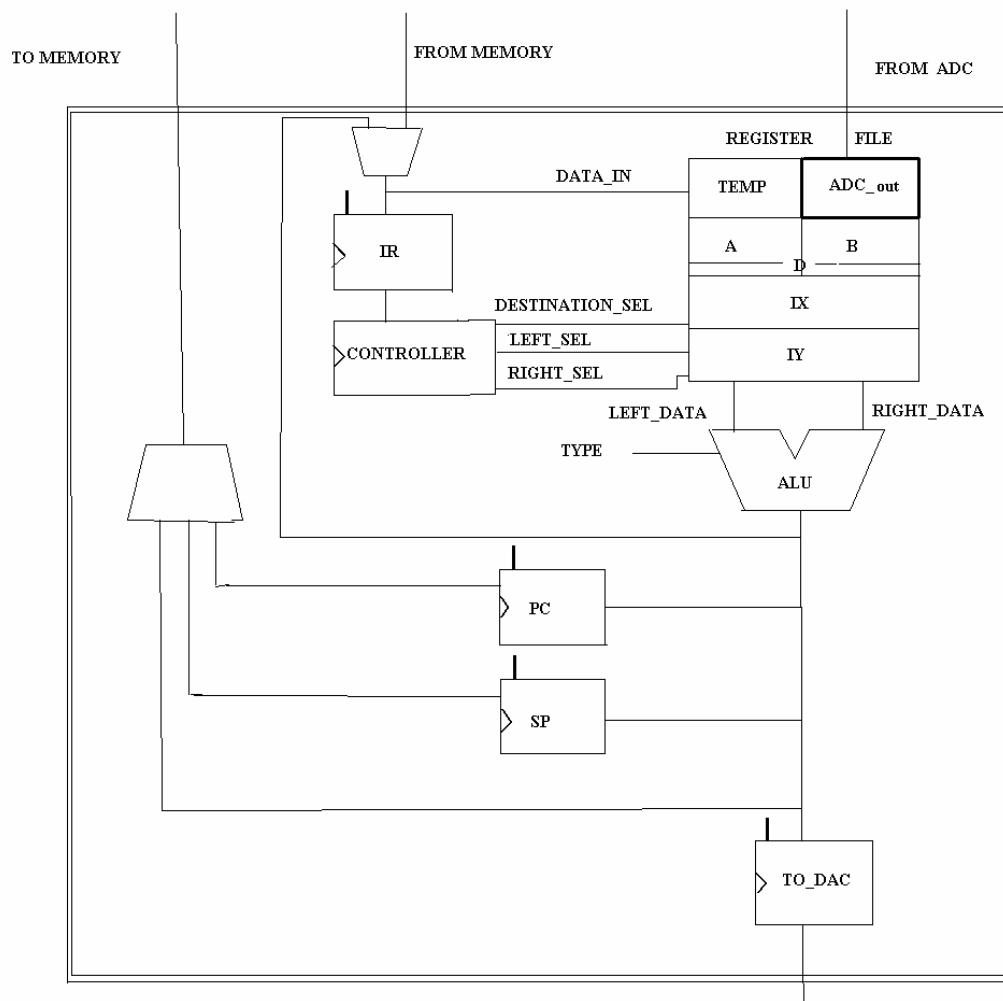

Figure 4. Detailed Block Diagram of Digital Controller ASIC

The Register-file block has a DATA\_in input and a control input that select the DESTINATION register to be written into. The Controller also provides two select inputs that determine which register contents are put out on the two OUTPUT buses. The output buses are directly connected to the ALU inputs.

The ALU output may be conveyed to the PC or SP registers, or it may be written back to memory or put out onto the DAC input line. The controller's various control inputs and the multiplexer hardware determine the operation to be performed according to the particular instruction.

The CPU supports all the common addressing modes including immediate, extended and direct modes. As a CISC processor, the CPU employs variable length instructions. Four instruction types are supported by the present digital controller design:

- 1) Register transfer
- 2) Register-memory
- 3) Arithmetic (including Multiplication and Division)
- 4) Fuzzy logic instructions

The hardware design of the digital controller has been laid out at the register level using a hardware description language (HDL). All of the instructions, including the fuzzy logic instructions, are undergoing final simulation. The next step that has also been initiated is the design of the memory controller that interfaces the CPU to the memory.

## **Conclusions**

In this paper we have presented the architecture and preliminary design of a fuzzy logic-based charge controller designed to interface a small, "chip-size" silicon solar cell to a wafer fab-based microbattery. The charge controller consists of three sections: a power stage comprising a step-down dc-dc converter, an analog/mixed signal block which integrates analog data acquisition, conditioning and conversion hardware, and a digital controller block which implements the fuzzy logic control algorithms. The design of these sections is at various stages of development with the digital controller block design furthest along. We expect to complete the design of the complete charge controller in the next few months and will have the individual sections fabricated as separate ASICs prior to integrating the entire design into a single chip.

## **Acknowledgements**

The authors gratefully acknowledge funding for this project from DARPA/U.S. Army Aviation and Missile Command (Contract No. DAAH01-01-C-R041) and useful discussions with Ms. Sherrie Burgett of U.S. Army Aviation & Missile Command, Redstone Arsenal, AL.

## References

- [1] J.N. Harb, J. Holladay, P. Humble, R. Barksdale, L. Salmon, D. Ryan, and R. LaFollette, "Electrochemical Behavior of Microscopic Secondary Batteries", *Procs. 34<sup>th</sup> IECEC*, Vancouver, Canada, Aug. 25-29, 1999
- [2] D. Ryan, R.M. LaFollette, and J.N. Harb, "Power Supply Concepts for Remote, Autonomous Sensors," *SAE Procs.*, Phoenix, AZ, April, 1999.
- [3] W.P. Mulligan, A. Terao, D.D. Smith, P.J. Verlinden, and R.M. Swanson, "Development of Chip-Size Solar Cells", *Proc. 28<sup>th</sup> IEEE Photovoltaic Specialists Conf.* (Anchorage, AK, Sept. 15-22, 2000) pp. 158-163
- [4] A. Stratakos, R. Sullivan, S.R. Sanders, and R.W. Broderson, "High Efficiency Low Voltage DC-DC Conversion for Portable Applications" in E. Sanchez-Sinencio and A.G. Andreou, eds., *Low-Voltage/Low-Power Integrated Circuits and Systems*" (IEEE Press, Piscataway, NJ, 1999), chap. 12.